

KAMIEŃ DEKORACYJNY I ELEWACYJNY

DECORATIVE AND ELEVATION STONE TILES

stones



TERAZ Z TECHNOLOGIĄ QR CODE - więcej informacji na tylnej okładce
NOW WITH QR CODE TECHNOLOGY - more info on the back cover





WEWNĘTRZNE
INTERIOR



LASCAR

IMITACJA KAMIENIA WULKANICZNEGO, ORAZ NIEJEDNOLITA FORMA PŁYTEK **LASCAR** PRZYWODZI NA MYŚL WNĘTRZA FRANCUSKICH REZYDENCJI.

IMITATION OF VOLCANIC STONE AND DIVERSIFIED FORM OF **LASCAR** TILES BRINGS TO MIND THE INTERIORS OF FRENCH RESIDENCES.

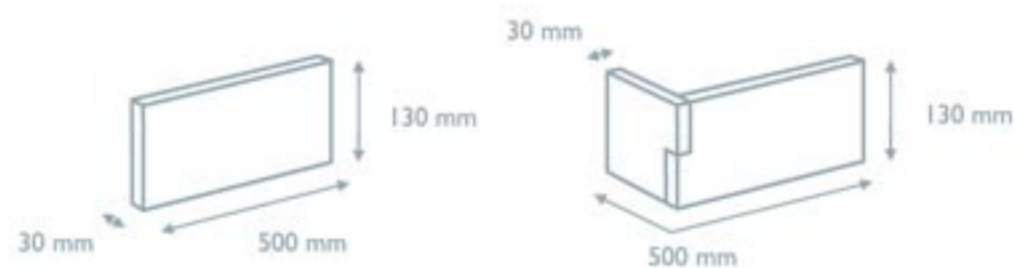

WEWNĘTRZNE
INTERIOR



MAYON

NIEZWYKŁA STRUKTURA ORAZ UNIKALNE PRZEBARWIENIA NADAJĄ PŁYTKOM I NAROŻNIKOM **MAYON** REALISTYCZNY WYGLĄD DROBNOŁUPANEGO PIASKOWCA.

INCREDIBLE STRUCTURE AND UNIQUE DISCOLORATION GIVES **MAYON** TILES AND CORNERS A REALISTIC LOOK OF FINELY SPLIT SANDSTONE.

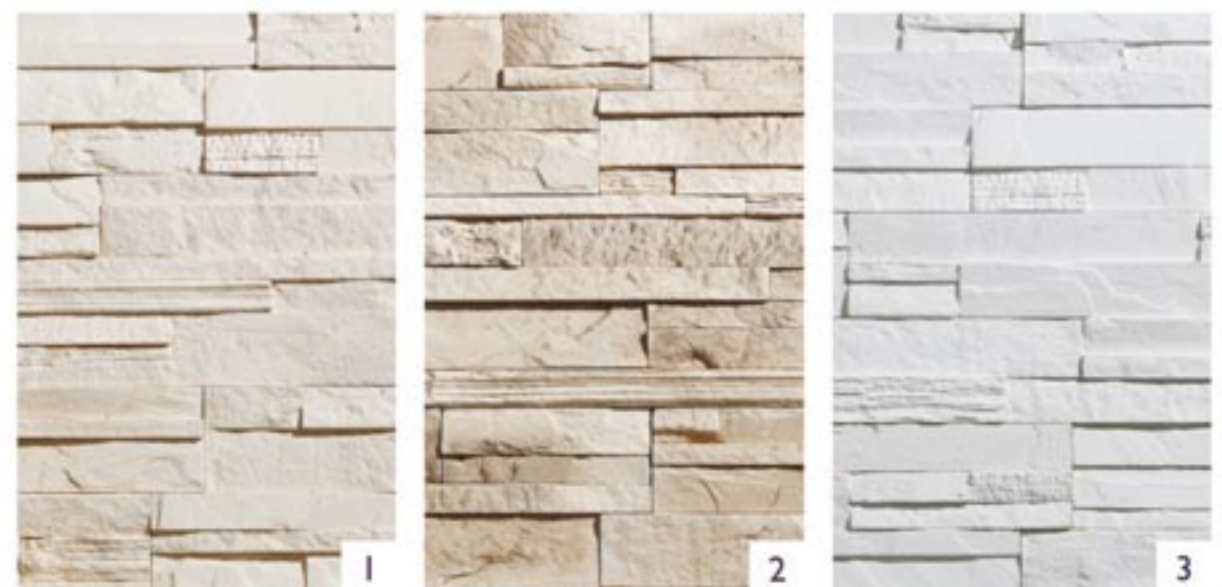

NEW

WEWNĘTRZNE
INTERIOR



INERIA

PŁYTKI KAMIENIOPODOBNE **INERIA** WYKONANE Z NIEZWYKŁĄ PRECYZJĄ, DOSKONAŁE SPRAWDZAJĄ SIĘ W KAŻDYM WNĘTRZU, NADAJĄC MU UROK I ATMOSFERĘ INDONEZYJSKICH WYSP.

IMITATE STONE TILES **INERIA** MADE WITH UNUSUAL PRECISION, ARE PERFECT FOR ANY INTERIOR, GIVING IT THE CHARM AND ATMOSPHERE OF THE INDONESIAN ISLANDS.



WEWNĘTRZNE
INTERIOR



NEW



OSHIMA

OSHIMA JEST KAMIENIEM DEKORACYJNYM O CHARAKTERYSTYCZNYM, GRUBYM PROFILU. ZAMKNIĘTY W FORMIE ŁATWEJ DO UŁOŻENIA DAJE MOŻLIWOŚĆ SZYBKIEJ INSTALACJI W KAŻDYM WNĘTRZU.

OSHIMA IS A NEW DECORATIVE STONE THAT ACCURATELY REPRODUCES THE TYPICAL COLOURS OF THE ZONES OF HIGHT MOUNTAIN. THE THICK PROFILE OF OSHIMA MAKES THE STONE EXPLICIT AND IMPRESSIVE. IDEAL AS COVERING INTERIOR WALLS.

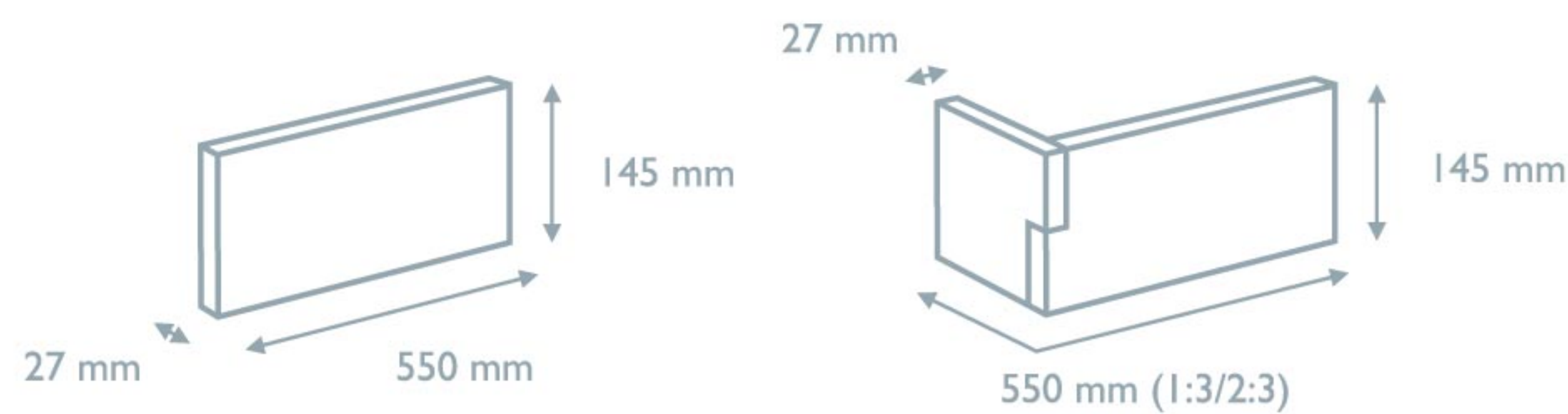

WEWNĘTRZNE
INTERIOR



PINATUBO



DZIĘKI DOSKONAŁEJ IMITACJI WAPIENIA SPOTYKANEGO NA PÓŁWYSPIE SYNAJ, PŁYTKI **PINATUBO** NADAJĄ WNĘTRZU ORYGINALNY CHARAKTER. ŚWIETNIE SPRAWDZAJĄ SIĘ W TOWARZYSTWIE EGIPSKICH PŁASKORZEŻB.

THANKS TO PERFECT IMITATION OF LIMESTONE FOUND ON THE SINAI PENINSULA, **PINATUBO** TILES GIVE THE INTERIOR AN ORIGINAL CHARACTER. THEY PROVE PERFECTLY IN THE SURROUNDING EGYPTIAN RELIEFS.

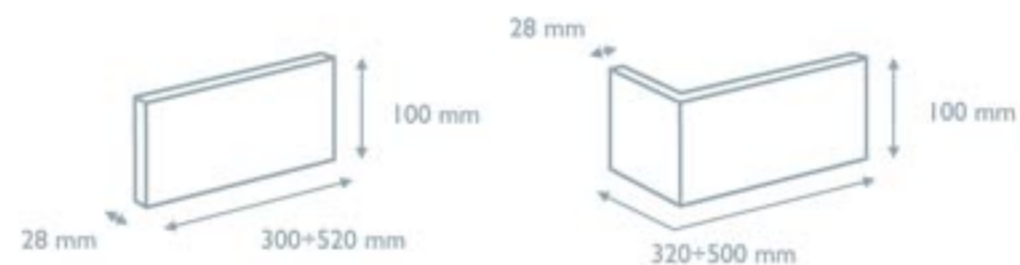

UNIWERSALNE
UNIVERSAL

NEW



KAMIEŃ NATURALNY NATURAL STONE

ZALETĄ KAMIENIA NATURALNEGO JEST NIEWĄTPLIWIE PIĘKNE WZORNICTWO ORAZ NIEPOWTARZALNY UROK NATURALNEJ FORMY. RÓŻNORODNOŚĆ BARW I STRUKTUR KAMIENIA POZWALA NA ZAAKCENTOWANIE INDYWIDUALNOŚCI KAŻDEGO WNĘTRZA, TARASU CZY SCHODÓW.

THE ADVANTAGE OF THE NATURAL STONE IS UNDOUBTEDLY A BEAUTIFUL DESIGN AND A UNIQUE CHARM OF THE NATURAL FORM. THE VARIETY OF STONE COLORS AND PATTERNS ALLOWS YOU TO HIGHLIGHT, INDIVIDUALITY OF EACH INTERIOR, TERRACE AND STAIRS.

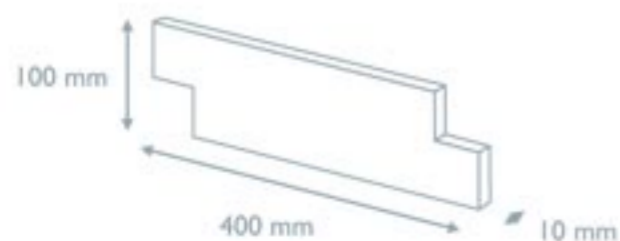

IVORY



RUSTY



GREY

UNIWERSALNE
UNIVERSAL

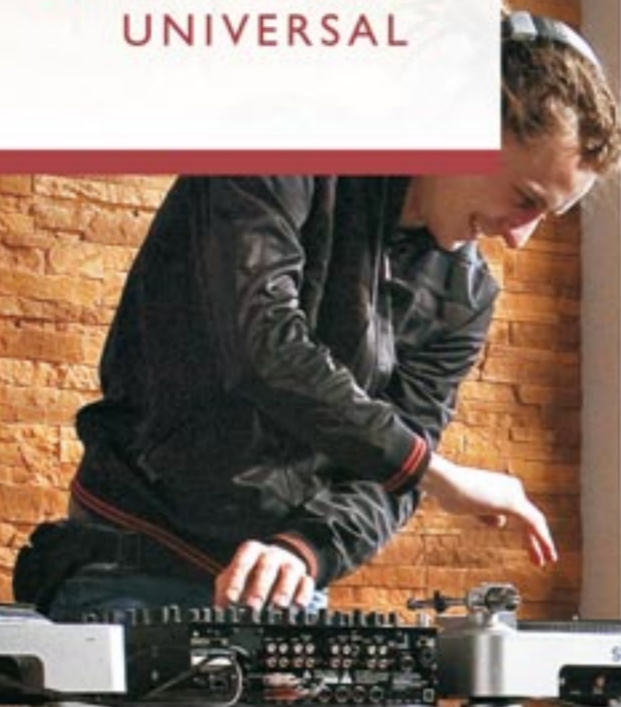

ETNA

ELEWACJA WYKOŃCZONA MROZODPORNYMI PŁYTKAMI **ETNA** TWORZY NIESAMOWITY EFEKT GRY ŚWIAŁŁA I CIENI DZIĘKI WYPUKŁEJ STRUKTURZE I BOGACTWU ZASTOSOWANYCH BARW.

ELEVATION WHICH IS FINISHED WITH FROST-RESISTANT **ETNA** TILES MAKES UP AN AMAZING EFFECT OF LIGHTS AND SHADOWS PLAY THANKS TO THE CONVEX STRUCTURE AND RICHNESS OF SHADES APPLIED.

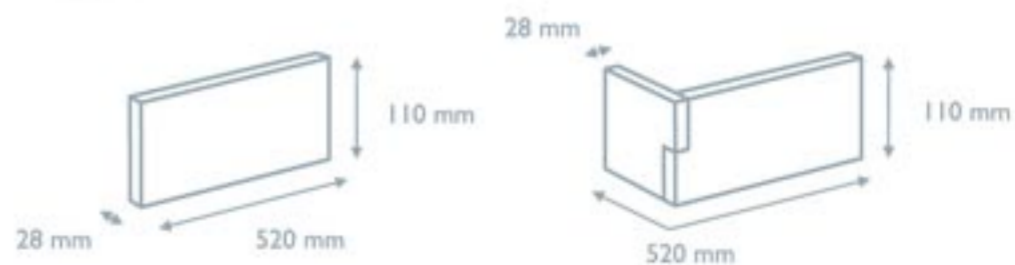

UNIWERSALNE
UNIVERSAL

NEW



MROZOODPORNE PŁYTKI **SAKURA** TO NATURALNE PIĘKNO ZAMKNIĘTE W NOWOCZESNEJ FORMIE. GŁĘBOKO RZEŻBIONE, LEKIE PŁYTKI ZACHWYCĄ KAŻDEGO PRECYZJĄ RĘCZNEGO WYKONANIA.

SAKURA IS A FROSTPROOF TILE WHICH COMBINES BEAUTY AND MODERN FORM. THE TILE IS HAND CAST WITH VISIBLE EDGES ON THE SURFACE.

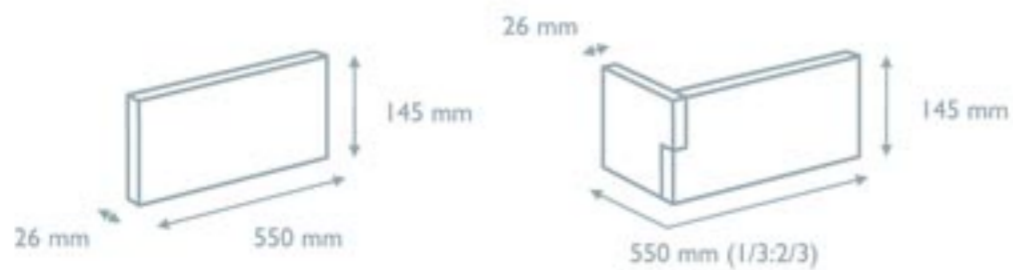

SAKURA



stones



JAMILA

stones
décor



125 x 50 cm (składa się z 2 części)
waga / weight: 20 kg



WEDŁUG PODAŃ AFRYKAŃSKICH BOGINI MATKA, PATRONKA KOBIEC. STRAŻNICZKA OGNISKA DOMOWEGO. ORYGINALNIE SKONSTRUOWANA, RĘCZNIE FORMOWANA, DWUELEMENTOWA PŁASKORZEŻBA **JAMILA** PRZYPOMINA STRUKTURĄ PIASKOWIEC. WYKONANA Z NIEZWYKŁĄ PRECYZJĄ ZACHWYCI KAŻDEGO SWOIM KSZTAŁTEM.

ACCORDING TO THE AFRICAN LEGENDS, THE GODDESS MOTHER, THE PATRONESS OF WOMEN. THE GUARDIAN OF HEARTH AND HOME. ORIGINALLY CONSTRUCTED, MANUALLY FORMED, TWOELEMENT RELIEF **JAMILA** REMINDS SANDSTONE IN TERMS OF THE STRUCTURE. MADE WITH EXTREME PRECISION SHALL DELIGHT EVERYONE WITH ITS SHAPE.

MING



97 x 97 cm (składa się z 5 części) waga / weight: 21 kg

PIĘCIOELEMENTOWA PŁASKORZEŻBA **MING** PRZEDSTAWIA MOTYWY 4 PÓR ROKU, SYMBOLIZUJĄC NIEZMIENNOŚĆ I STABILNOŚĆ, A TYM SAMYM POWODZENIE. PŁASKORZEŻBA WYKONANA JEST Z MODYFIKOWANEGO GIPSU MODELOWEGO, RĘCZNIE MALOWANEGO NATURALNYMI BARWNIKAMI.

CONSISTING OF FIVE ELEMENTS MOTIVES **MING** RELIEF PRESENTS THE MOTIFS OF 4 SEASONS OF THE YEAR SYMBOLIZING THE UNCHANGEABILITY AND STABILITY AND AT THE SAME TIME THE SUCCESS. THE RELIEF IS MADE OF MODIFIED MODEL GYPSUM, MANUALLY PAINTED WITH NATURAL COLOURS.

EGYPT

COLLECTION

stones
decor

waga / weight: 8,2 kg



Rameses 45 x 59 cm



Seti 48 x 61 cm



Amenhotep 48 x 61 cm

ZODIAC

20 x 20 cm

waga / weight: 0.85 kg



Cała kolekcja dostępna jest na stronie www.stones.com.pl
The entire collection is available on www.stones.com.pl

stones

ELEMENTY OGRODOWE GARDEN ELEMENTS

PŁYTY TARASOWE TERRACE PANELS



PODKŁADY KOLEJOWE WOOD SLABS

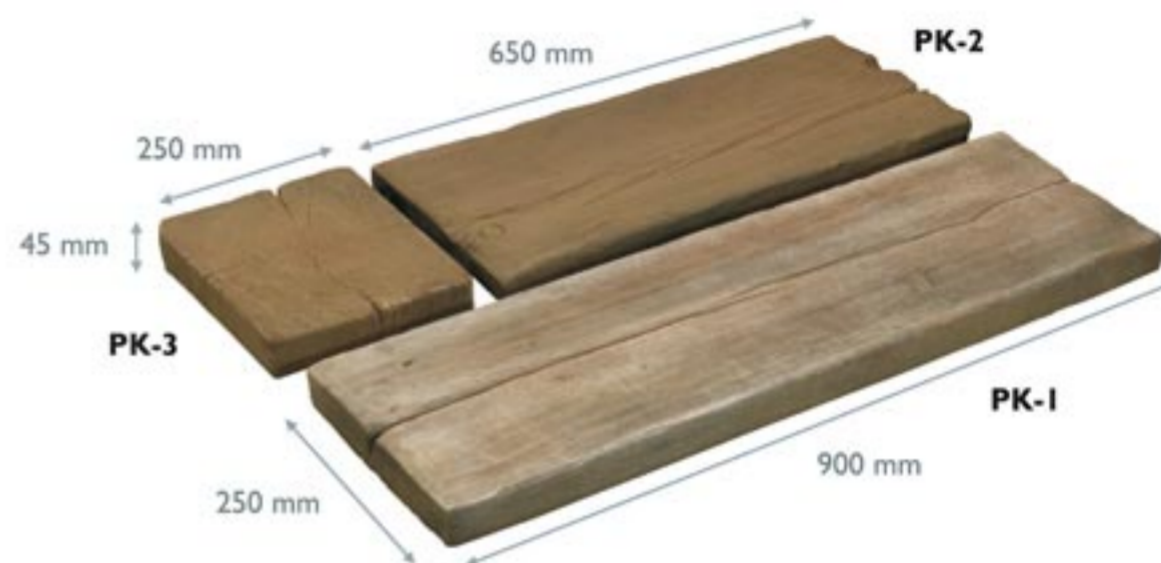

KRAŻKI DREWNOPODOBNE WOOD STEPS





G-5

Środek do gruntowania
Surface primer

Wydajność / Efficiency: 0,05-0,2 l / m²



T-5

Klej gipsowy
Gypsum adhesive

Wydajność / Efficiency: 1 kg / m²



K-15

Zaprawa klejąca do wewnątrz/zewnątrz
Adhesive for interior/exterior

Wydajność / Efficiency: 1 kg / m²



E-7

Klej uniwersalny
Universal adhesive

Wydajność / Efficiency: 1 kg / m²



S-2

Środek do konserwacji
Brick tiles impregnant

Wydajność / Efficiency: 0,3-1 kg / m²



KOMSIL

Impregnat do obudów kominkowych
Fireplace housing impregnant

Wydajność / Efficiency: 0,25-0,66 l / m²



PRODUKT / PRODUCT	ZAWARTOŚĆ OPAKOWANIA / PACKAGE CONTENT				WAGA OPAKOWANIA / PACKAGE WEIGHT		NA PALECCIE / ON A PALLET [opakowania / packages]	ZALECANE AKCESORIA / RECOMMENDED ACCESSORIES				
	PLYTKI bez fugi / z fugą* TILES without / with joint* [m²]	PLYTKI / TILES [szt. / pcs]	NAROŻNIKI / CORNERS [mb / m]	NAROŻNIKI / CORNERS [szt. / pcs]	PLYTKI / TILES [kg]	NAROŻNIKI / CORNERS [kg]		GRUNT / SURFACE PRIMER	KLEJ / ADHESIVE	FUGA / JOINT	IMPREGNAT / IMPREGNANT	
WEWNĘTRZNE / INTERIOR	LASCAR	0,65	10	1,30	10	12,2	11,5	45	G-5	T-5 / E-7	-	S-2
	INERIA	0,64	8	1,17	8	12,4	12,4	72	G-5	T-5 / E-7	-	S-2
	MAYON	0,90	10	2,00	10	17,5	17,5	42	G-5	T-5 / E-7	-	S-2
	OSHIMA	0,96	12	1,70	12	17	17	45	G-5	T-5 / E-7	-	S-2
	PINATUBO	1,00	31	2,00	20	20	13	45	G-5	K-15 / E-7	-	S-2
UNIWERSALNE / UNIVERSAL	KAMIEŃ NATURALNY	0,42	12	-	-	11	-	96	G-5	K-15 / E-7	-	S-2
	ETNA	1,00	18	2,00	18	22,5	22,5	48	G-5	K-15 / E-7	-	S-2
	SAKURA	0,96	12	1,74	12	24,5	22,5	36	G-5	K-15 / E-7	-	S-2

Firma STONES nie ponosi odpowiedzialności za błędy w druku i pomyłki pisarskie. Prezentowane materiały mają charakter poglądowy i nie stanowią oferty w rozumieniu obowiązujących przepisów. Wymiary, masy i kolory produktów itp. mają wyłącznie charakter orientacyjny. Z uwagi na technikę druku kolorystyka produktów może nieznacznie różnić się od rzeczywistej. Firma STONES zastrzega sobie prawo dokonywania zmian technicznych i technologicznych prezentowanych produktów.

STONES Company is not responsible for printing errors and typographical mistakes. Materials presented are only for illustration and does not constitute an offer within the meaning of applicable law. Dimensions, weights and colors of products, etc. are approximate. Due to the printing of color may differentiate from the real. STONES Company reserves the right to make technical and technological changes of presented products.

* Szerokość fugi - 1 cm. / Joint width - 1 cm.



Kody QR - jak to działa?



Teraz w katalogu STONES przy produktach umieszczony jest kwadratowy **kod QR**. Jest to system specjalnych kodów, których zeskanowanie odpowiednim telefonem - smartfonem, prowadzi bezpośrednio do strony www o tym produkcie.

Aby telefon mógł odczytywać te kody, należy na nim zainstalować jeden z bezpłatnych programów do kodów QR. Program taki można pobrać w zależności od typu systemu w telefonie z np. Google Play, AppStore lub Ovi.



DYSTRYBUCJA

STONES J.R.M. Skucik Sp.j.

ul. Kluczborska 5b, 46-243 Bogacica, Poland
tel. +48 77 469 84 95, fax +48 77 469 84 18
biuro@stones.com.pl, www.stones.com.pl